

**ZAG**ZAVOD ZA  
GRADBENIŠTVO  
SLOVENIJESLOVENIAN  
NATIONAL BUILDING  
AND CIVIL ENGINEERING  
INSTITUTEčlan EOTA  
Member of EOTA**Dimičeva 12**  
**1000 Ljubljana, Slovenija**

Tel.: +386 (0)1-280 44 72, 280 45 37

Fax: +386 (0)1-280 44 84

E-pošta: info.ta@zag.si

http://www.zag.si

## European Technical Assessment

**ETA-15/0361**  
**of 17.06.2015***English version prepared by ZAG*

### I GENERAL PART

Komerčno ime

*Trade name*

Imetnik tehnične ocene

*Holder of Technical Assessment*

Družina proizvalca

*Product family*

Proizvodni obrat

*Manufacturing plant*

Ta Evropska tehnična ocena vsebuje

*This European Technical Assessment contains*

Ta Evropska tehnična ocena je izdana na podlagi Uredbe (EU) št. 305/2011 na osnovi

*This European Technical Assessment is issued in accordance to Regulation (EU) No 305/2011, on the basis of***Apolo MEA Quick fix anchor BA and BA A4****Apolo MEA Befestigungssysteme GmbH****Industriestraße 6****86356 Aichach****Germany****Torzijsko kontrolirano zatezno pocinkano in nerjaveče kovinsko sidro velikosti M8, M10, M12 in M16 za vgradnjo v nerazpokani beton***Torque controlled expansion anchor made of galvanised and stainless steel of sizes M8, M10, M12 and M16 for use in non-cracked concrete***Plant 14**

11 strani vključno s 7 prilogami, ki so sestavni del te ocene

*11 pages including 7 annexes, which form an integral part of the document*

Smernice za evropska tehnična soglasja ETAG 001 – del 1 in 2, izdaja 2013, ki se uporablja kot EAD

*Guideline for European Technical Approval ETAG 001 – part 1 and 2, edition 2013, used as EAD*

Translations of this European Technical Assessment in other languages shall fully correspond to the original issued document and should be identified as such.

Communication of this European Technical Assessment, including transmission by electronic means, shall be in full (excepted the confidential Annex(es) referred to above). However, partial reproduction may be made, with the written consent of the issuing Technical Assessment Body. Any partial reproduction has to be identified as such.

## **II SPECIFIC PART OF THE EUROPEAN TECHNICAL APPROVAL**

### **1 Technical description of the product**

The Apolo MEA Quick fix anchor BA in the range of M8, M10, M12 and M16 is an anchor made of galvanised steel. The Apolo MEA Quick fix anchor BA A4 in the same range is an anchor made of stainless steel. Anchors are placed into a drilled hole and anchored by torque-controlled expansion.

For the installed anchor see Figure A2 given in Annex A1.

### **2 Specification and intended use**

The performances given in Chapter 3 are only valid if the anchor is used in compliance with the specifications and conditions given in Annex B.

The provisions made in this European Technical Assessment are based on an assumed working life of the anchor of 50 years. The indications given on the working life cannot be interpreted as a guarantee given by the manufacturer, but are to be regarded only as a means for choosing the right products in relation to the expected economically reasonable working life of the works.

### **3 Performance of the product and references to the methods used for this assessment**

#### **3.1 Mechanical resistance and stability (BWR 1)**

Basic work requirements for mechanical resistance and stability are listed in Annex C.

#### **3.2 Safety in case of fire (BWR 2)**

Not relevant.

#### **3.3 Hygiene, health and environment (BWR 3)**

Regarding dangerous substances contained in this European Technical Assessment, there may be requirements applicable to the products falling within its scope (e.g. transported European legislation and national laws, regulations and administrative provisions). In order to meet provisions of the regulation (EU) No 305/2011, these requirements need also to be complied with, when they apply.

#### **3.4 Safety in use (BWR 4)**

For basic work requirements safety in use the same criteria are valid as for basic work requirements mechanical resistance and stability.

#### **3.5 Protection against noise (BWR 5)**

Not relevant.

#### **3.6 Energy economy and heat retention (BWR 6)**

Not relevant.

#### **3.7 Sustainable use of natural resources (BWR 7)**

For sustainable use of natural resources no performance was determined for this product.

#### **3.8 General aspects relating to fitness for use**

Durability and serviceability are only ensured if specifications of intended use according to Annex B1 are kept.

#### 4 Assessment and verification of constancy of performance

According to the decision 96/582/EC of the European Commission<sup>1</sup> the system of assessment and verification of constancy of performance (see Annex V to regulation (EU) No 305/2011) given in the following table apply.

Product	Intended use	Level of class	System
Metal anchors for use in concrete	For fixing and/or supporting to concrete, structural elements (which contributes to the stability of the works) or heavy units	-	1

#### 5 Technical details necessary for the implementation of the AVCP system

##### 5.1 Tasks for the manufacturer

The manufacturer shall exercise permanent internal control of production of concerned product. All the elements, requirements and provisions adopted by the manufacturer shall be documented in a systematic manner in the form of written policies and procedures, including records of results performed. This production control system shall ensure that the product is in conformity with this European Technical Assessment.

The manufacturer may only use raw materials stated in the technical documentation of this European Technical Assessment.

The factory production control shall be in accordance with the Control plan which is a part of the technical documentation of this European Technical Assessment. The Control plan<sup>2</sup> is laid down in the context of the factory production control system operated by the manufacturer and deposited at Slovenian National Building and Civil Engineering Institute (ZAG Ljubljana). The results of factory production Control shall be recorded and evaluated in accordance with the provisions of the control plan.

The manufacturer shall, on the basis of a contract, involve a body, which is notified for the tasks referred to in a section 4 in the field of anchors in order to undertake the actions laid down in section 5.2. For this purpose the Control plan referred to in sections 5.1 and 5.2 shall be handed over by the manufacturer to the notified body involved.

The manufacturer shall make a Declaration of performance, stating that the construction product is in conformity with the provisions of this European Technical Assessment.

<sup>1</sup>  
<sup>2</sup>

Official Journal of the European Communities L 254 of 8.10.1996

The Control plan is a confidential part of the technical documentation of this European Technical Assessment, but not published together with the ETA, and handed over only to the notified body or bodies involved in the procedure of attestation of conformity.

## **5.2 Tasks for the notified bodies**

The notified body shall retain the essential points of its actions defined in Annex V of Regulation (EU) No. 305/2011 for system 1 and state results obtained and conclusions drawn in a written report.

The notified certification body involved by the manufacturer shall issue an EC certificate of constancy of performance the product stating the conformity with the provisions of this European Technical Assessment.

In cases where the provisions of the European Technical Assessment and its Control plan are no longer fulfilled the notified body shall withdraw the certificate of constancy of performance and inform the Slovenian National Building and Civil Engineering Institute (ZAG Ljubljana) without delay.

Issued in Ljubljana on 17.06.2015

Signed by:

Franc Capuder, M.Sc., Research Engineer

*Head of Service of TAB*

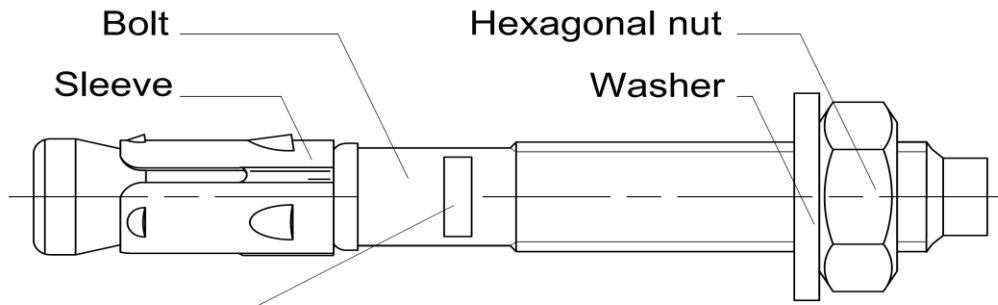

**Marking:** Identifying mark: N  
 Anchor identity: T (through bolt)  
 Category<sup>\*1)</sup>: Z (zinc plated)  
 Thread size: SS (stainless steel)  
 Max. fixture thickness: M8 ... M16  
 Examples: BA: NTZ 10/20 - zinc plated  
 BA A4: NTSS 10/20 - stainless steel A4

**Figure A1:** Apolo MEA Quick fix anchor BA / BA A4

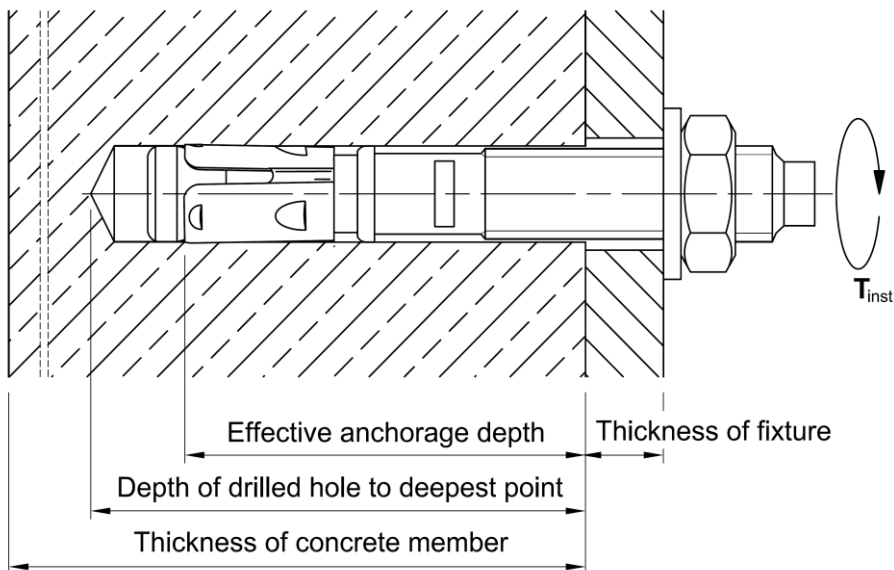

**Figure A2:** Apolo MEA Quick fix anchor BA / BA A4

<p><b>Apolo MEA Quick fix anchor BA and BA A4</b></p>	<p><b>Annex A1</b></p>
<p><b>Product description</b> Product and intended use</p>	

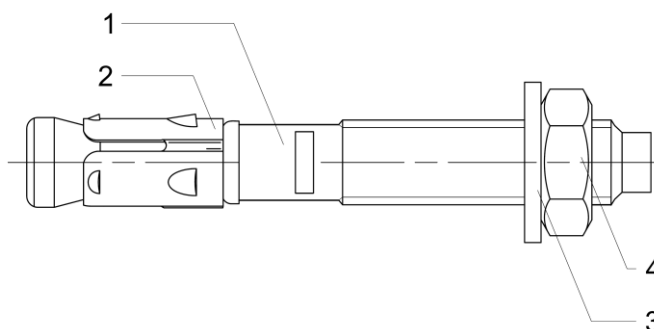
**Table A1:** Materials for Apolo MEA Quick fix anchor BA

Part	Component	Diameter	Material	$f_{yk}$ [N/mm <sup>2</sup> ]	$f_{uk}$ [N/mm <sup>2</sup> ]
1	Anchor body (bolt)	M10, M12	Cold forged steel acc. to EN 10263-2; zinc electroplated acc. to EN ISO 4042 $\geq 5\mu\text{m}$ and bright passivated	560	660
		M8, M16		475	560
2	Expansion sleeve	M8 – M16	Hot-dip coated steel strip Z275 acc. to EN 10346		
3	Washer	M8 – M16	Steel to DIN 125/EN ISO 7089, DIN 440/EN ISO 7094, DIN 9021/EN ISO 7093; zinc electroplated acc. to EN ISO 4042 $\geq 5\mu\text{m}$ and bright passivated.		
4	Hexagonal nut	M8 – M16	Steel to DIN 934/EN ISO 4032, property class 8; zinc electroplated acc. to EN ISO 4042 $\geq 5\mu\text{m}$ and bright passivated.		

**Table A2:** Materials for Apolo MEA Quick fix anchor BA A4

Part	Component	Diameter	Material	$f_{yk}$ [N/mm <sup>2</sup> ]	$f_{uk}$ [N/mm <sup>2</sup> ]
1	Anchor body (bolt)	M8 – M16	Cold forged stainless steel acc. to EN 10088-3;	530	600
2	Expansion sleeve	M8 – M16	Stainless steel strip acc. to EN 10088-3;		
3	Washer	M8 – M16	Stainless steel acc. to DIN 125/EN ISO 7089, DIN 440/EN ISO 7094, DIN 9021/EN ISO 7093;		
4	Hexagonal nut	M8 – M16	Stainless steel acc. to DIN 934/EN ISO 4032, property class 80;		

**Apolo MEA Quick fix anchor BA and BA A4**

**Product description**  
Materials

**Annex A2**

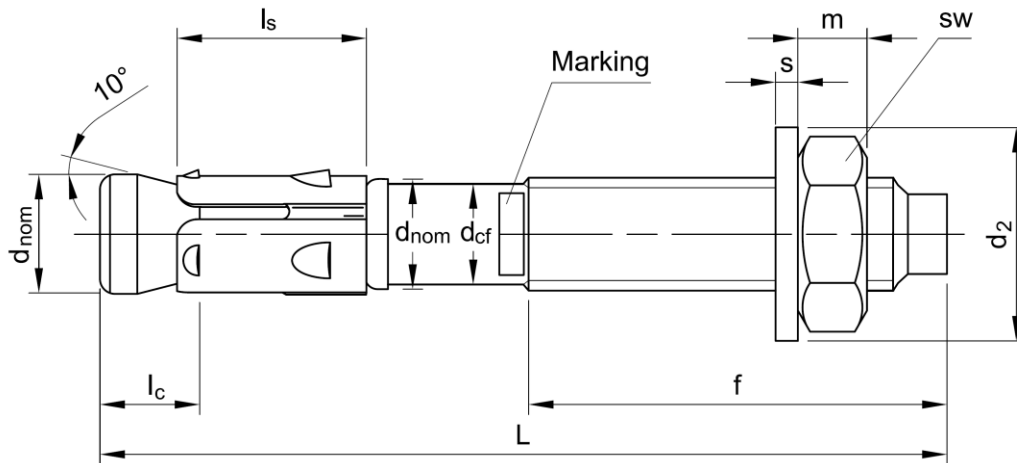

**Table A3: Dimensions**

Main dimensions		Stud bolt		Cone bolt		Expansion sleeve	Washer			Hexagonal nut		
Anchor type	Size	L	f	d <sub>cf</sub>	d <sub>nom</sub>	l <sub>c</sub>	l <sub>s</sub>	s	d <sub>1</sub>	d <sub>2</sub>	sw	m
		[mm]	[mm]	[mm]	[mm]	[mm]	[mm]	[mm]	[mm]	[mm]	[mm]	[mm]
8 / 0....358	M8	62....420	22....220	7,1	8	20,9	15,9	≥ 1,6	≥ 8,4	≥ 16	13	≥ 6,5
10 / 0....338	M10	82....420	37....215	9,0	10	25,7	17,9	≥ 2,0	≥ 10,5	≥ 20	≥ 16	≥ 8,0
12 / 0....322	M12	98....420	48....210	10,8	12	30,3	19,1	≥ 2,5	≥ 13,0	≥ 24	≥ 18	≥ 10,0
16 / 0....302	M16	118....420	60....202	14,6	16	38,1	26,3	≥ 3,0	≥ 17,0	≥ 30	24	≥ 13,0

**Apolo MEA Quick fix anchor BA and BA A4**

**Product description**  
Dimensions

**Annex A3**

**Specifications of intended use**

**Anchorage subjected to:**

- Static, quasi static load and fire.

**Base materials:**

- Non-cracked concrete.
- Reinforced and unreinforced normal weight concrete of strength class C20/25 at minimum and C50/60 at maximum according to EN 206-1:2000/A2:2005.

**Use conditions (Environmental conditions):**

- The Apolo MEA Quick fix anchor BA may be used in structures subjected to dry internal conditions.
- The Apolo MEA Quick fix anchor BA A4 may be used in concrete subject to dry internal conditions and also in concrete subject to external atmospheric exposure (including industrial and marine environment), or exposure in permanent damp internal conditions, if no particular aggressive conditions exist. Such particular aggressive conditions are e.g. permanent, alternating immersion in seawater or splash zone of seawater, chloride atmosphere of indoor swimming pools or atmosphere with extreme chemical pollution (e.g. desulphurization plants or road tunnels where de-icing materials are used).

**Design:**

- Anchorages are designed under the responsibility of an engineer experienced in anchorages and concrete work.
- Anchorages under static and quasi-static actions are designed in accordance with ETAG 001, Annex C, design method A, Edition August 2010.
- Verifiable calculation notes and drawings are prepared taking into account of the load to be anchored. The position of the anchor is indicated on the design drawings (e.g. position of the anchor relative to reinforcement or to supports, etc.).

**Installation:**

- Anchor installation carried out by appropriately qualified personnel and under supervision of the person responsible for technical matters of the site.
- Use of the anchor only supplied by the manufacturer without exchanging the components of an anchor.
- Anchor installation in accordance with the manufacturer's specification and drawings and using the appropriate tools.
- Checks before placing the anchor to ensure that the strength class of the concrete in which the anchor is to be placed is in the range given and is not lower than that of the concrete to which the characteristic loads apply for.
- Check of concrete being well compacted, e.g. without significant voids.
- Effective anchorage depth, edge distances and spacing not less than the specified values without minus tolerances.
- Thickness of the fixture corresponding to the range of required thickness value for the type anchor.
- Cleaning of the hole of drilling dust.
- Positioning of the drill holes without damaging the reinforcement.
- Application of specified torque moment using a calibrated torque wrench.
- In case of aborted hole, drilling of new hole at a minimum distance of twice the depth of the aborted hole, or smaller distance provided the aborted drill hole is filled with high strength mortar and no shear or oblique tension loads in the direction of aborted hole.

**Apolo MEA Quick fix anchor BA and BA A4**

**Intended use**  
Specification

**Annex B1**



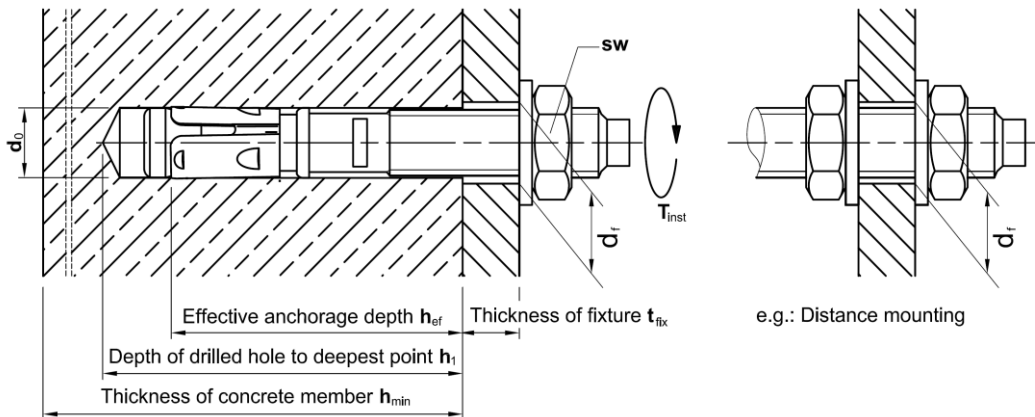

**Table B1: Installation data**

Apolo MEA Quick fix anchor BA and BA A4			Anchor size			
			M8	M10	M12	M16
Drill hole diameter	$d_0$	[mm]	8	10	12	16
Cutting diameter at the upper tolerance limit (maximum drill bit diameter)	$d_{cut,max} \leq$	[mm]	8,45	10,45	12,50	16,50
Depth of drilled hole	$h_1 \geq$	[mm]	60	75	90	110
Effective anchorage depth	$h_{ef}$	[mm]	45	60	70	85
Diameter of clearance hole of the fixture	$d_r$	[mm]	9	12	14	18
Thickness of the fixture	$t_{fix,min...max}$	[mm]	0...358	0...338	0...322	0...302
Width of flats	SW	[mm]	13	$\geq 16$	$\geq 18$	24
Torque moment	BA	$T_{inst}$	[Nm]	20	35	50
	BA A4					70

**Table B2: Minimum thickness of concrete member, spacing and edge distance**

Apolo MEA Quick fix anchor BA and BA A4			Anchor size			
			M8	M10	M12	M16
Minimum thickness of concrete member	$h_{min}$	[mm]	100	120	140	170
Minimum spacing	$s_{min}$	[mm]	50	55	60	70
	$c \geq$	[mm]	50	80	90	120
Minimum edge distance	$c_{min}$	[mm]	50	50	55	85
	$s \geq$	[mm]	50	100	145	150

**Apolo MEA Quick fix anchor BA and BA A4**

**Intended use**  
Installation data

**Annex B2**

**Table C1:** Characteristic values for Tension loads in case of static and quasi-static loading for design method A acc. ETAG 001-Annex C

Essential characteristics			Performance				
			M8	M10	M12	M16	
<b>Installation parameters</b>							
$d_0$	Nominal diameter of drill bit	[mm]	8	10	12	16	
$h_{ef}$	Effective anchorage depth	[mm]	45	60	70	85	
$h_{min}$	Minimum thickness of concrete member	[mm]	100	120	140	170	
$T_{inst}$	Torque moment	BA	20	35	50	120	
		BA A4			70		
$s_{min}$	Minimum spacing	for $c \geq$	[mm]	50	55	60	70
			[mm]	50	80	90	120
$c_{min}$	Minimum edge distance	for $s \geq$	[mm]	50	50	55	85
			[mm]	50	100	145	150
<b>Tension steel failure mode</b>							
$N_{Rk,s}$	Characteristic tension steel failure	BA	[kN]	13	26	38	69
		BA A4	[kN]	15	24	35	75
$\gamma_{MsN}$	Partial safety factor	[-]	1,4				
<b>Pull-out failure mode</b>							
$N_{Rk,p}$	Characteristic pull-out failure in non-cracked concrete	[kN]	9	16	20	35	
$\gamma_2$	Partial safety factor	[-]	1,2			1,0	
$\gamma_{Mp}$		[-]	1,8			1,5	
$s_{cr,N}$	Characteristic spacing	[mm]	135	180	210	255	
$c_{cr,N}$	Characteristic edge distance	[mm]	68	90	105	128	
$\psi_C$ C30/37	Increasing factor for $N_{Rk,p}$ in non-cracked concrete	[-]	1,10				
$\psi_C$ C40/50		[-]	1,15				
$\psi_C$ C50/60		[-]	1,20				
<b>Splitting failure mode</b>							
$s_{cr,sp}$	Characteristic spacing	[mm]	180	240	280	340	
$c_{cr,sp}$	Characteristic edge distance	[mm]	90	120	140	170	
$\gamma_{Msp}$	Partial safety factor	[-]	1,8			1,5	
<b>Displacement under tension load</b>							
Non-cracked concrete C20/25							
$N$	Service tension load	[kN]	3,6	6,3	7,9	16,7	
$\delta_{N0}$	Short term displacement	[mm]	0,045	0,358	0,059	0,149	
$\delta_{N\infty}$	Long term displacement	[mm]	0,204	0,358	0,204	0,204	
Non-cracked concrete C50/60							
$N$	Service tension load	[kN]	4,3	7,6	9,5	20,0	
$\delta_{N0}$	Short term displacement	[mm]	0,029	0,071	0,072	0,220	
$\delta_{N\infty}$	Long term displacement	[mm]	0,653	0,653	0,653	0,653	

Apolo MEA Quick fix anchor BA and BA A4

Design acc. to ETAG 001-Annex C  
 Characteristic resistance under Tension loads – BWR 1

Annex C1

**Table C2:** Characteristic values for Shear loads in case of static and quasi-static loading for design method A acc. ETAG 001-Annex C

Essential characteristics				Performance			
				M8	M10	M12	M16
<b>Shear steel failure</b>							
$V_{Rk,s}$	Characteristic shear steel failure	BA	[kN]	10	18	23	44
		BA A4	[kN]	11	17	25	47
$M^0_{Rk,s}$	Bending moment characteristic failure	BA	[Nm]	21	49	86	186
		BA A4	[Nm]	22	45	79	200
$\gamma_{MsV}$	Partial safety factor		[-]	1,5			
<b>Shear concrete pry-out and edge failure</b>							
$k$	Factor in equation (5.6) of ETAG 001 Annex C § 5.2.3.3		[mm]	1,0	2,0		
$l_{ef}$	Effective anchorage depth		[mm]	45	60	70	85
$d_{nom}$	Diameter of anchor		[mm]	8	10	12	16
$\gamma_{Mc}$	Partial safety factor		[-]	1,8			1,5
<b>Displacement under shear load</b>							
$V$	Service shear load		[kN]	4,8	8,1	11,0	20,9
$\delta_{V0}$	Short term displacement		[mm]	1,43	1,34	2,02	2,66
$\delta_{V\infty}$	Long term displacement		[mm]	2,15	2,01	3,03	4,00

Apolo MEA Quick fix anchor BA and BA A4

Design acc. to ETAG 001-Annex C  
Characteristic resistance under Shear loads – BWR 1

Annex C2